

Bronco Body Modification Guide

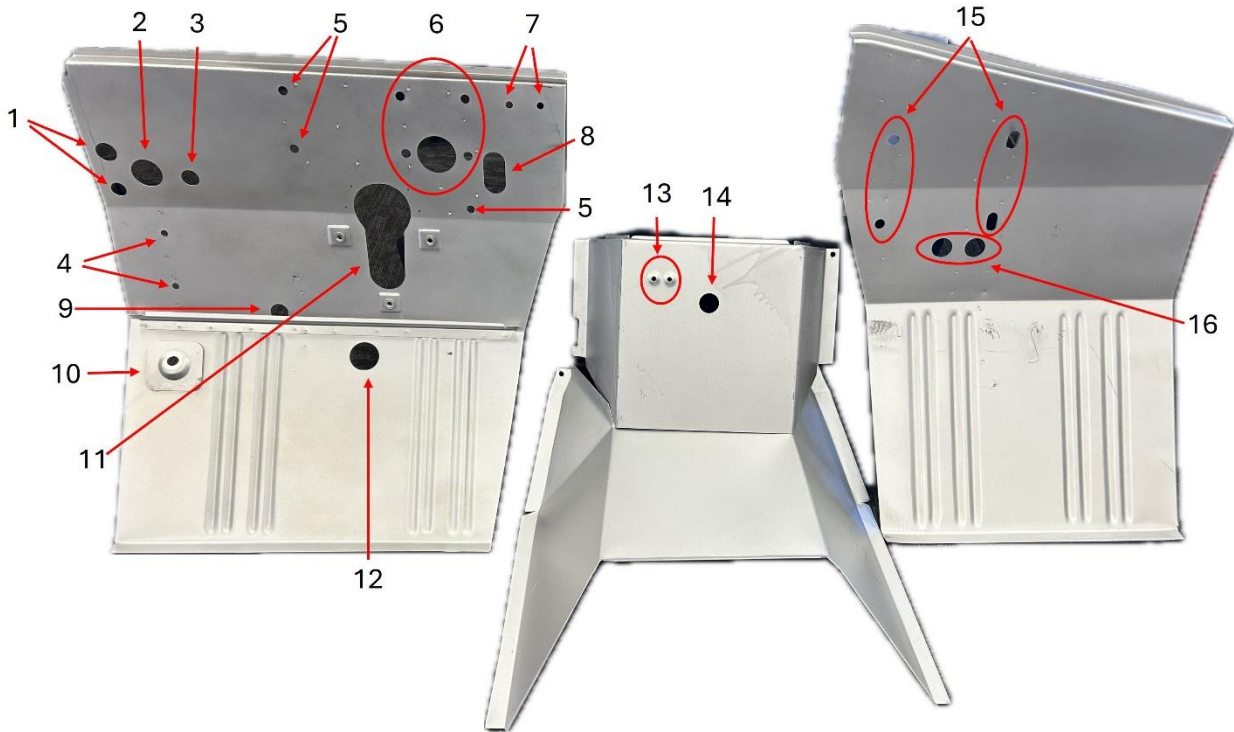

- | | |
|---|---|
| <input type="checkbox"/> 1. Auxiliary Wiring (\$100) | <input type="checkbox"/> 9. Vent Box Drain (\$50) |
| <input type="checkbox"/> 2. Main Wiring Harness (\$50) | <input type="checkbox"/> 10. Parking Brake Floor Reinforcement (\$100) |
| <input type="checkbox"/> 3. Speedometer Cable (\$50) | <input type="checkbox"/> 11. Steering Column (Coyote Application) (\$50) |
| <input type="checkbox"/> 4. Emergency Brake Booster Support (\$50) | <input type="checkbox"/> 12. Clutch Linkage (\$50) |
| <input type="checkbox"/> 5. Pedal Assembly (\$50) | <input type="checkbox"/> 13. Unused (\$50) |
| <input type="checkbox"/> 6. Master Cylinder: Notch for Hydro Boost (\$50) | <input type="checkbox"/> 14. Heater Cable (\$50) |
| <input type="checkbox"/> 7. Accelerator Pedal Bracket Throttle Spring (\$50) | <input type="checkbox"/> 15. Heater Box Mount (\$100) |
| <input type="checkbox"/> 8. Accelerator Pedal Linkage (\$50) | <input type="checkbox"/> 16. Heater Hose (\$100) |

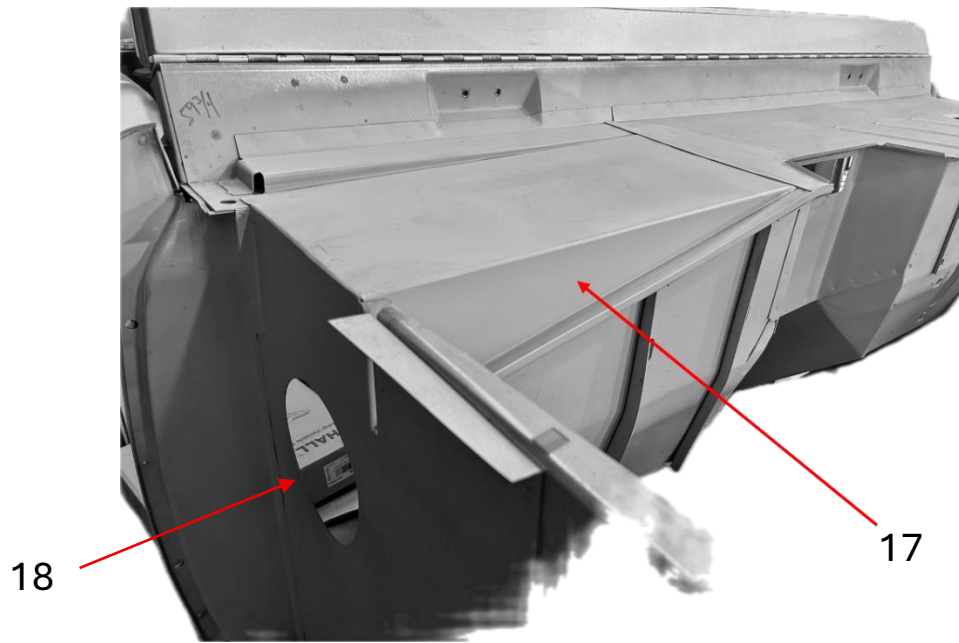

- 17. Cowl Top Modification for Vintage Air Air Box Circle (**\$300**)
- 18. Air Box Circle (**\$150**)
- 19. CPU Port for Coyote Engine (**\$50**)
- 20. Harness Port for Coyote Engine (**\$150**)
- 21. Notch Corner for Kincer Coyote Engine Clearance (not shown in pic) (**\$100**)

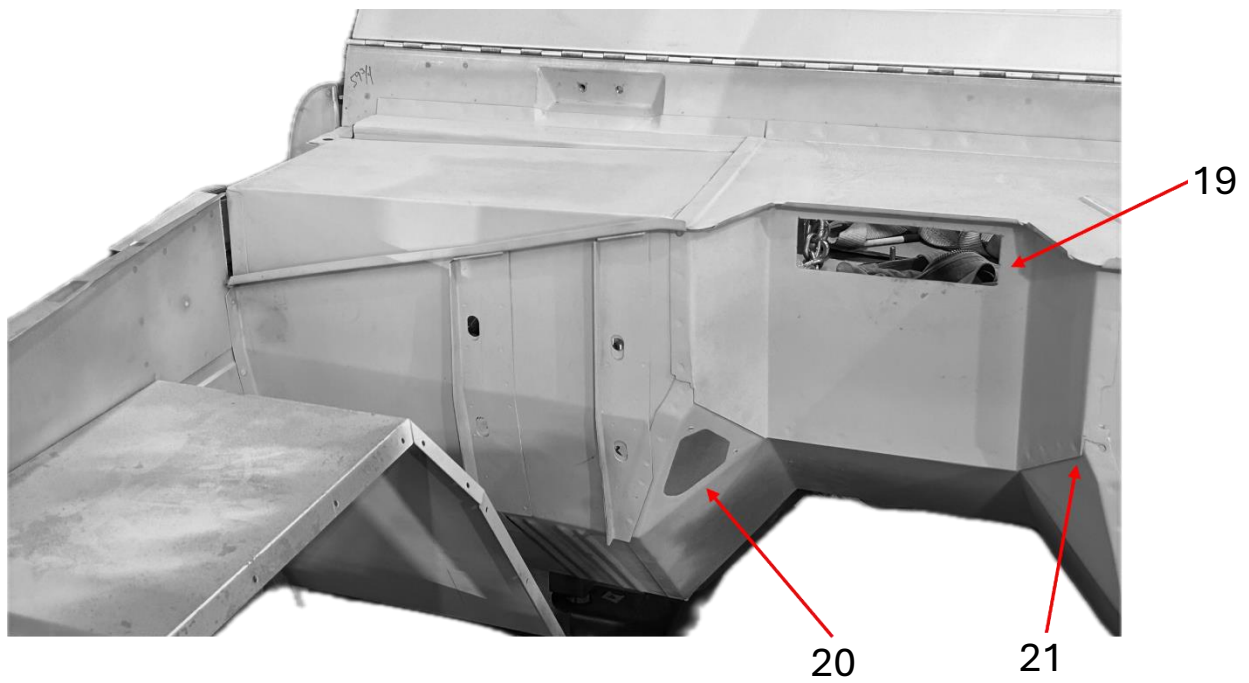

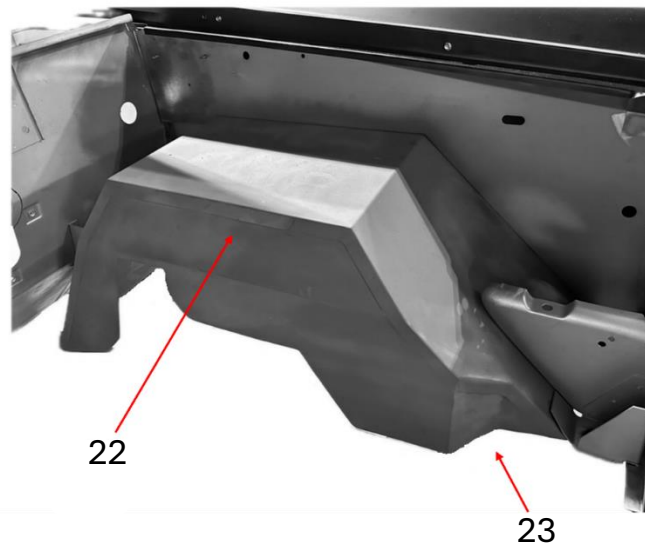

- 22. Wheel Well Narrowed and Notched for Coil Spring Tower for Coyote Application **(\$200)**
- 23. Wheel Well Modified for Power Steering Box **(\$150)**

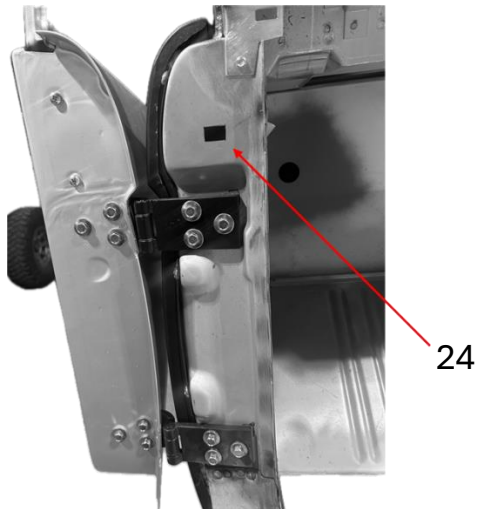

- 24. Original Dome Light Port Plugged and Modified for Traditional Switch, Driver & Passenger Side (can use switch for dome light and amp switch) **(\$150)**

Vintage Air Packages:

- 25. Vintage Air - Gen 4 Modification (15-17 above plus drain hole drilled) **(\$400)**
- 26. Vintage Air – Gen 5 Modification (15-17 above plus drain hole drilled) **(\$400)**